

GigaSTAR[®]

Application Note

Display Link



Revision 1.2

July 2001

Table of Contents:

Introduction	3
Features	3
GigaSTaR Digital Display & Multimedia Link	4
Analog Graphic Sources	5
GigaSTaR Digital Display Data Distribution	7
Building Blocks (Line Repeater, Y Repeater)	7
GigaSTaR Repeater Applications	9
Daylight Display Walls	9
Passenger Information Systems	9
Architectures	10

List of Illustrations:

Figure 1: GigaSTaR Multimedia Link.....	4
Figure 2: Adapting the GigaSTaR parallel interface to Digital Graphic Cards and TFT Displays.....	4
Figure 3: Analog / Digital Graphics Conversion.....	5
Figure 4: GigaSTaR Display Link with STP Copper Cable.....	5
Figure 5: GigaSTaR Display Link with Multimode Fiber.....	6
Figure 6 : Line Repeater with GigaSTaR.....	7
Figure 7 : Y Repeater with GigaSTaR.....	7
Figure 8 : Line Repeater with Digital Display Data Interface.....	7
Figure 9 : Jitter Accumulation: GigaSTaR Link vs Synchronous System.....	8
Figure 10 :Setup with test points.....	8
Figure 11 : Pixel Clock and Data Timing.....	8
Figure 12 : Display Wall with GigaSTaR Line Repeater.....	9
Figure 13 : Passenger Information System with GigaSTaR Line- and Y-Repeater.....	9

Introduction

Today's digital TFT and plasma displays are used in various applications such as passenger and public information systems and high quality industrial control panels. These applications require reliable links to transfer pixel data over extended distances without deteriorating the signal quality.

The GigaSTaR link, a robust and reliable gigabit serial link, can easily be configured as a high performance display link simply by adopting the graphics interface to the 36-bit parallel data interface of the GigaSTaR devices.

In this configuration, the GigaSTaR link is not only a highly reliable gigabit interconnect offering maximum stability and robustness even in a harsh industrial environment. It is also a very innovative display link with unique features and functionality.

By transmitting display data over only one twisted pair of copper cables or fiber optic cable, the GigaSTaR Display Link offers maximum flexibility for building distributed display networks over long distances.

Combined with its local clock domains, the GigaSTaR's asynchronous parallel interface safely prevents the accumulation of jitter in segmented systems, a unique feature compared to existing synchronous systems where clock jitter is accumulated with every segment.

One GigaSTaR serial channel with a payload data rate of 1.18 GBit/s can easily transmit graphics data for XGA resolution (1024 x 768, 60 Hz, 18-bit color) over long distances without need for a repeater while still leaving approximately 300 MBit/s of bandwidth for all other types of digital signals (multi-channel CD/DVD audio/video data, control data or other CPU data).

For technical details about GigaSTaR devices see the product datasheet on our web site: (<http://www.inova-semiconductors.com>)

Features

- Long distance transfers of high resolution graphics data without line repeaters over one pair of copper lines or fibre optic cables (up to 50 m with shielded twisted pair copper cable, and up to 550 m with multimode fiber cable)
- No crosstalk or skew effects; digital noise-free imaging quality
- Self-synchronizing receiver, no external logic required
- Multiple cascaded repeaters possible (no clock jitter accumulation)
- Simple repeater building blocks (line, T and Y repeater) for flexible signal distribution and extended display networks
- 1.18 GBit/s per channel (XGA mode), scalable for higher resolutions (SXGA, UXGA)
- Fully AC-coupled link (signal line and shield)
- Maximum EMI and noise immunity due to differential CML signals
- Standard small form factor and low cost connectors (2 pins per channel)
- 3.3 V supply voltage. Low power dissipation of 1 watt per device (typical)

GigaSTaR Digital Display & Multimedia Link

The GigaSTaR link is a fully transparent system interconnect equipped with a 36-bit parallel transmit-and-receive data interface. Data coding, link control, data and clock recovery functions are all performed by the GigaSTaR device and do not require any further external control logic.

To adapt today's wide range of display data interfaces to the generic GigaSTaR parallel data interface, some external glue logic is required which easily fits into a small standard programmable logic device (PLD).

The generic, fully transparent interface of the GigaSTaR is a unique feature that builds a true multimedia link by sharing the link bandwidth between graphics, audio and control data. For example, a transfer of display data in XGA mode (1024 x 768) with 60 Hz refresh rate and 18-bit color still leaves some 300 MBit/s available for audio and any other digital data.

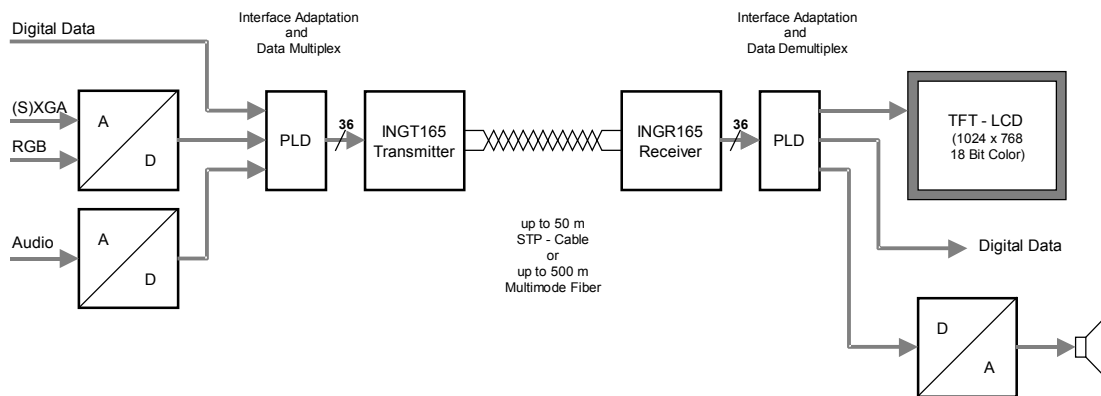

Figure 1: GigaSTaR Multimedia Link

The digital display interface with 36-bit (two pixels per clock), control signals and additional auxiliary digital data are multiplexed and mapped to the 36-bit width GigaSTaR interface at the transmitter and receiver. The required glue logic fits in most CPLDs (e.g. Lattice M4A3)

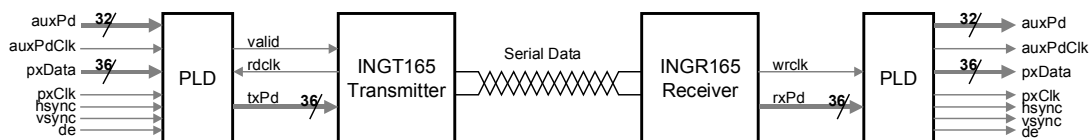

Figure 2: Adapting the GigaSTaR parallel interface to Digital Graphic Cards and TFT Displays

Analog Graphic Sources

Most sources for graphics such as cameras, DVD players and PC graphic outputs (VGA/XGA) still provide analog signals. To connect such a source to a digital TFT display, an extra adapter is required to convert the analog signals (XGA, RGB, Y/C etc.) to digital format.

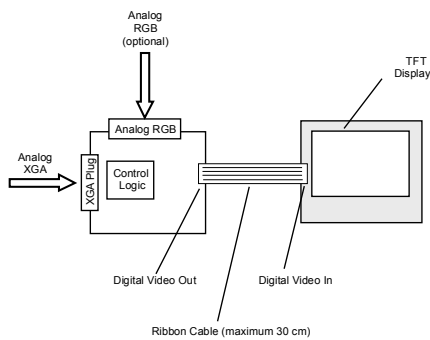

Figure 3: Analog / Digital Graphics Conversion

A typical implementation of the GigaSTaR link in combination with an analog / digital converter is shown in Figures 4 and 5. By adopting the link to the digital output of the converter board, the signal can be transmitted over distances of 50 m with shielded twisted pairs (STP) of copper cable (4) or distances of up to 500 m with multimode fiber (5).

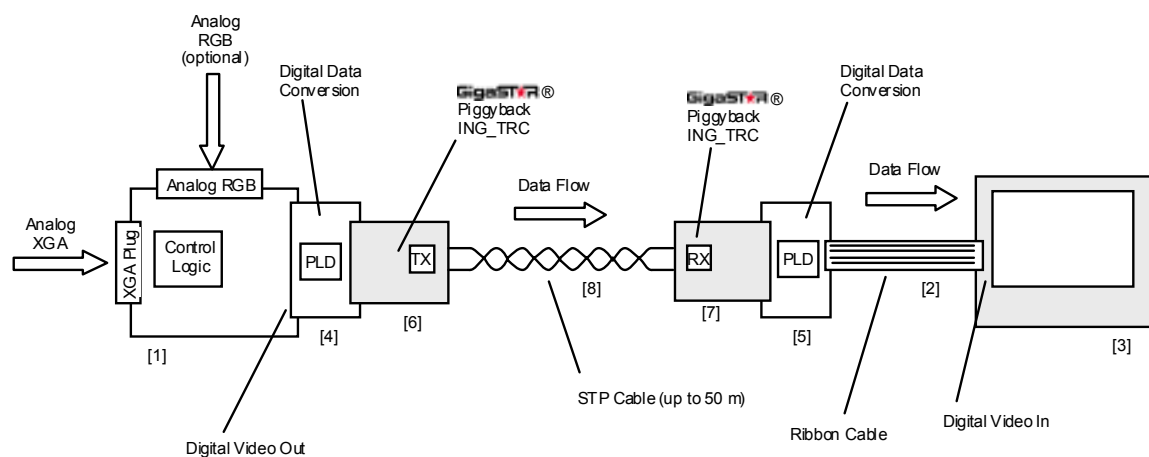

Figure 4: GigaSTaR Display Link with STP Copper Cable

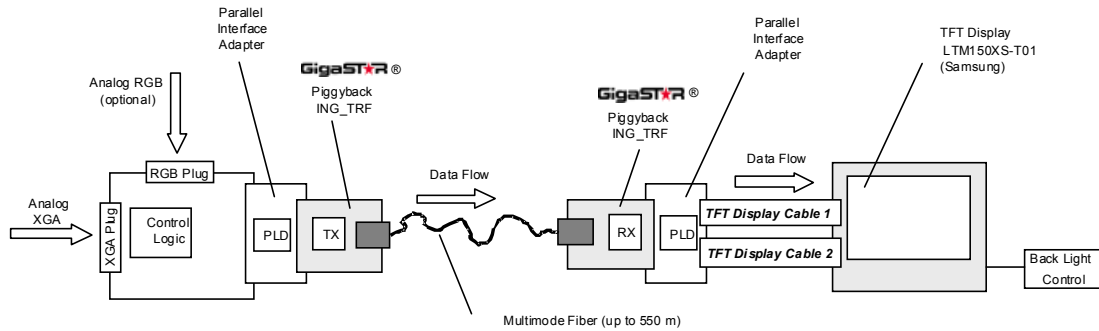

Figure 5: GigaSTaR Display Link with Multimode Fiber

Reference	Component	Supplier	Ordering Code
[1], [2], [3]	TFT Display with Control Logic	WBC/EBV	PACK-SA 150 IRIS Samsung, 15" XGA TTL
[4], [5]	PLD	Lattice Semiconductors	M4A3-256/128 (see note)
[6], [7]	Piggyback for STP Copper Cable	Inova Semiconductors	ING_TRC
[8]	Cable	W.L. Gore	GGSC1608-xx (*)
[9], [10]	Piggyback for Fiber Optic Cable	Inova Semiconductors	ING_TRF
[11]	Multimode Fiber Optic Cable	Various	Multimode Fiber Optic Cable

(*) e.g. 30 m cable length: GGSC1608-30

Table 1: List of components with reference indices

Note:

The application as described in Figure 4) is realized as “GigaSTaR Display Kit” (device title: ING_DK1) also shown on the cover page of this application note.

Please contact your local sales representative for more information about this display kit or for PLD programming information.

GigaSTaR Digital Display Data Distribution

Building Blocks (Line Repeater, Y Repeater)

Flexible, long distance display data distribution networks are the backbone of today's and the future's multimedia information and entertainment systems.

Such networks must offer maximum flexibility in distributing the graphic data over long distances while still providing the bandwidth to meet today's and tomorrow's requirements for high image resolution.

While the GigaSTaR link already supports very extended distances without any signal repetition, a repeater is typically required to establish an access point for the TFT display(s) or to build complex signal distribution schemes with so-called "Y" or line repeaters.

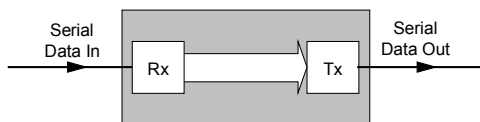

Figure 6 : Line Repeater with GigaSTaR

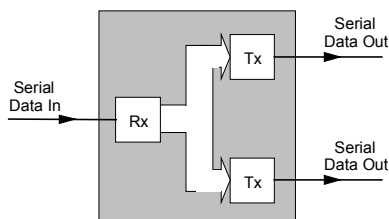

Figure 7 : Y Repeater with GigaSTaR

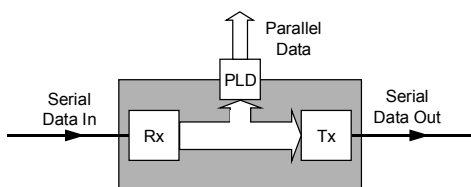

Figure 8 : Line Repeater with Digital Display Data Interface

Repeating display signals is usually associated with signal deterioration as a result of jitter accumulation. Existing display link systems with synchronous clock schemes are usually restricted to 2-3 repeaters until the accumulating clock jitter causes the image quality to deteriorate to unacceptable levels.

The GigaSTaR link operates with its own local reference clock instead of cascading the recovered clock at each repeater stage, this means there is almost no limit to the number of signal repeaters.

Supported by a very low bit error rate of $10 \text{ E-}13$ and fully self-synchronizing GigaSTaR receivers, even highly complex distribution schemes can be configured without any noticeable deterioration in the quality of the image. The distance between two repeaters is not restricted and may reach up to 50 meters for copper STP cable and up to 550m for fiber optic cable.

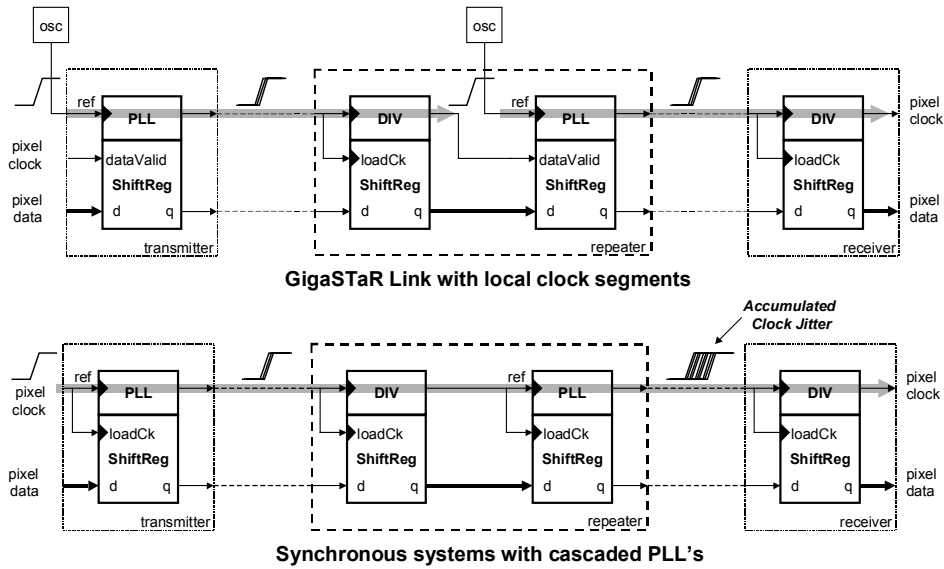

Figure 9 : Jitter Accumulation: GigaSTaR Link vs Synchronous System

The setup shown below of a GigaSTaR display link with 8 cascaded repeaters and an overall distance of about 150 meters (copper cable) illustrates the constant high quality of the recovered pixel clock and data even at the final repeater stage.

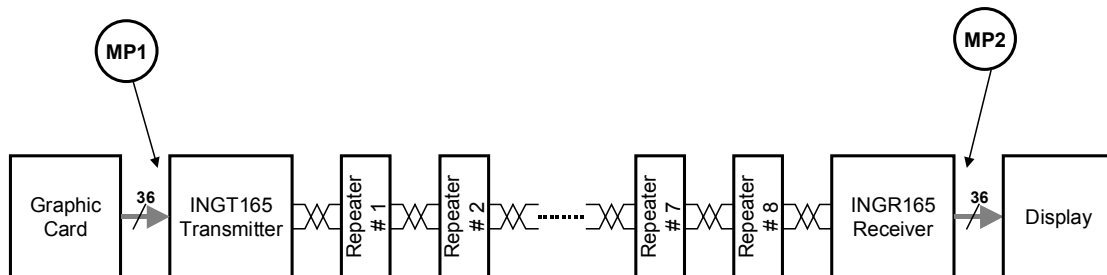

Figure 10 : Setup with test points

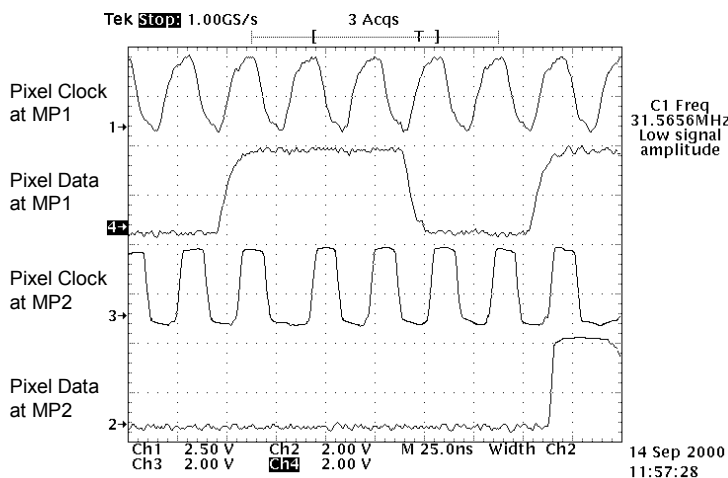

Figure 11 : Pixel Clock and Data Timing

GigaSTaR Repeater Applications

Daylight Display Walls

A daylight display wall typically consists of several hundred segments, each displaying a fraction of the whole picture. This application requires intensive routing of the display data from segment to segment.

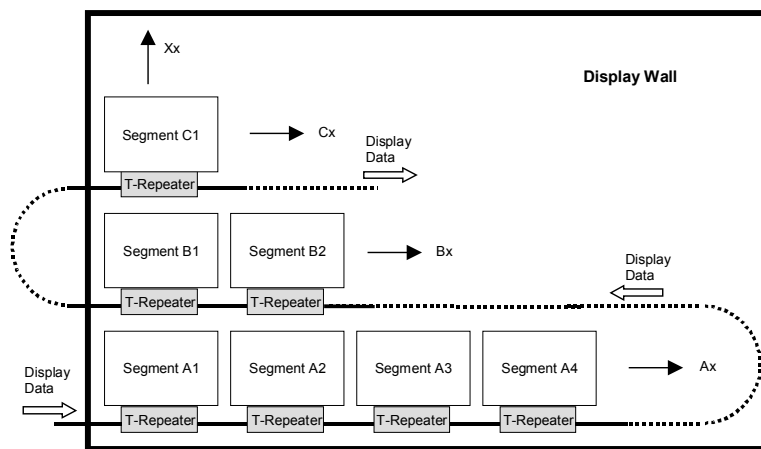

Figure 12 : Display Wall with GigaSTaR Line Repeater

Passenger Information Systems

Modern information systems require broadcasting of display data with multiple access points for displays.

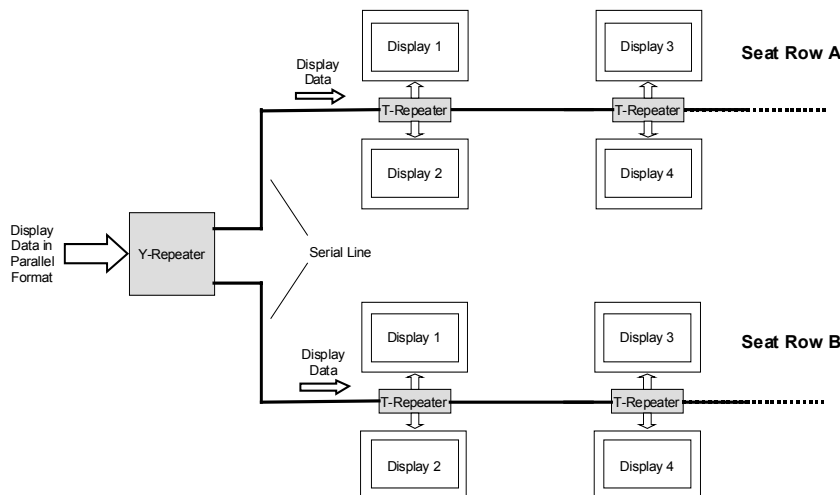
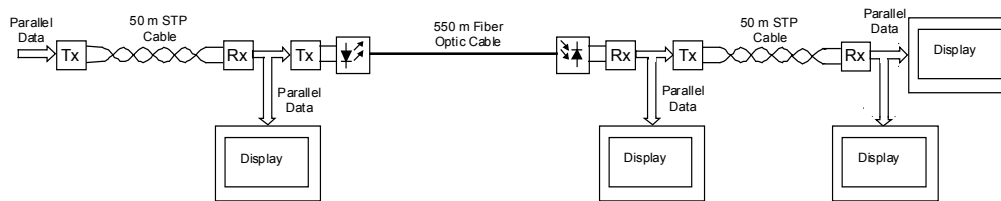

Figure 13 : Passenger Information System with GigaSTaR Line- and Y-Repeater

Architectures

The facility to use a robust, high-speed serial transmission technology like GigaSTaR for distributing high-resolution graphics over distance without any shortcomings or limitations is a breakthrough in the design of innovative display systems.

Complemented by modular repeater building blocks - line and Y repeaters with or without a parallel outlet for the digital display – and with the option to choose from different transmission media to reach distances up to 50 m (copper cable) or 550 m (multimode fiber), there are almost unlimited options for digital display distribution networks.



Example 1: Combined medium / long distance transmission

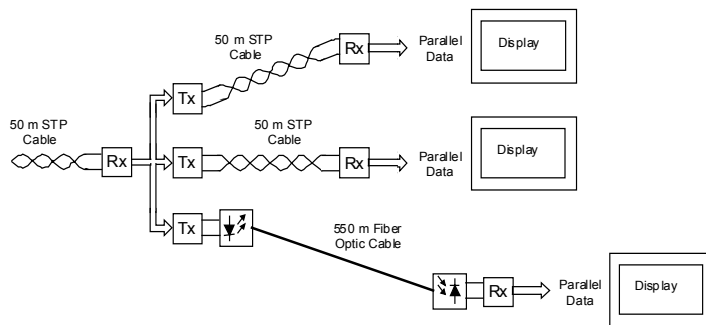

Example 2: Point-to-multipoint, medium / long distance transmission

Inova Semiconductors GmbH
Grafinger Str. 26
D-81671 Munich, Germany
Phone: +49 (0)89 / 45 74 75 - 60
Fax: +49 (0)89 / 45 74 75 - 88
E-mail: info@inova-semiconductors.de
URL: <http://www.inova-semiconductors.com>

GigaSTAR[®]

is a registered trademark of Inova Semiconductors GmbH.

All other trademarks or registered trademarks are the property of their respective holders.

Inova Semiconductors GmbH does not assume any liability arising from the application or use of the product described herein; nor does it convey any license under its patents, copyright or any rights of others.

Inova Semiconductors products are not designed, intended or authorized for use as components in systems to support or sustain life, or for any other application in which the failure of the product could create a situation where personal injury or death may occur.

The information contained in this document is believed to be current and accurate as of the publication date. Inova Semiconductors GmbH reserves the right to make changes at any time in order to improve reliability, function or performance to supply the best product possible.

Inova Semiconductors GmbH assumes no obligation to correct any errors contained herein or to advise any user of this text of any correction if such be made.

© Inova Semiconductors GmbH 2005. All rights reserved.