

**GigaSTAR**<sup>®</sup>

## Application Note

# Interfacing GigaSTaR<sup>®</sup> to Fiber Optical Modules

Revision 1.1

*This Application Note provides information necessary to design interconnections between GigaSTaR<sup>®</sup> RF I/Os and AC coupled PECL interfaces.*

---

**INTRODUCTION**

To achieve data transmission over long distances fiber optic cables are the standard link medium. The GigaSTaR<sup>®</sup> 's Transmitter and Receiver devices enable the user to build up an optical GigaSTaR<sup>®</sup> link easily (maximum data rate 1.32 Gbit/s) and gives the user bridging capabilities of up to 550 m through fiber optic multimode cables.

The present application notes supply all information needed for an optical data transmission system using multimode transceiver modules and gives detailed information about the interconnections between GigaSTaR<sup>®</sup> RF I/Os (Current Mode Logic) and PECL with AC coupling.

For technical details and parameters of all boards and the GigaSTaR<sup>®</sup> products see the product data sheets, the current revisions are available as pdf-files on the Inova Semiconductors Web-page: <http://www.inova-semiconductors.com>

**OVERVIEW**

The following functional diagram shows the 2.64 Gbit/s Full-Duplex Serial Link using two optical Gigabit Transceiver Modules in connection with two pairs of GigaSTaR<sup>®</sup> devices each.

To shorten layout and design periods Fiber Optical Piggyback Boards are available from Inova Semiconductors (Order No.: ING\_TRF) containing the fiber optical module plus GigaSTaR<sup>®</sup> Transmitter and Receiver devices.

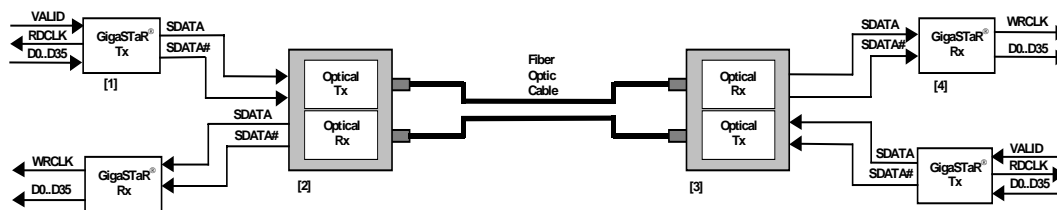

Figure 1: 2.64 Gbit/s Full-Duplex Serial Link

**SHORT DESCRIPTION**

GigaSTaR<sup>®</sup> Transmitter [1] is transforming parallel data into a serial bit stream. The optical Transmitter of the multimode module [2] is sending optical data to the optical Receiver [3] which converts optical data into electrical data. Serial data are de-serialized within the GigaSTaR<sup>®</sup> Receiver [4] and re-transformed into parallel data format (36 bit @ maximum 33 MHz).

### IMPLEMENTATION OF THE OPTICAL TRANSCEIVER

The following sections supply background information regarding the GigaSTaR<sup>®</sup> Serial Interface and AC-coupled PECL-Interfaces needed for implementing an optical transceiver into the serial line. The following figure shows a block diagram of GigaSTaR<sup>®</sup> devices combined with optical transceivers.

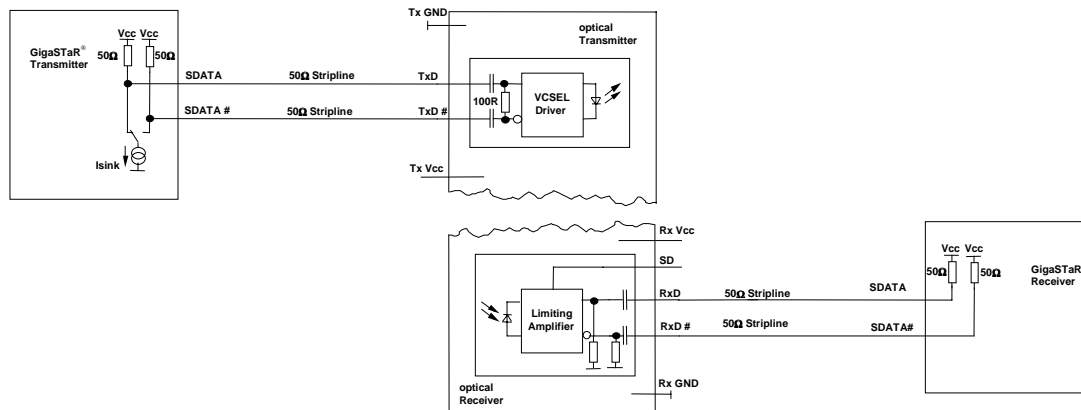

Figure 2: Optical Transmitter/Receiver and GigaSTaR<sup>®</sup> devices

### SHORT DESCRIPTION

The serial interface of the GigaSTaR<sup>®</sup> device provides Current Mode Logic (CML). These CML inputs and outputs can easily be adapted to most optical modules.

The Optical Transmitter Module features PECL inputs (internally AC coupled) which directly fit the GigaSTaR<sup>®</sup> CML outputs. The GigaSTaR<sup>®</sup> CML input and the AC-coupled PECL outputs of the Optical Receiver also fit together perfectly.

The differential serial outputs of the GigaSTaR<sup>®</sup> draw dynamic current of 8 mA through the AC-coupled differential input impedance (100 Ω) of the Optical Transmitter which results in a differential voltage swing of 800 mV at the Optical Transmitter input.

The differential output of the Optical Receiver works with an internal Open Line Termination with coupling capacitors. These outputs draw a dynamic current flow through the internal resistors of the GigaSTaR<sup>®</sup> Receiver (each 50 Ω).

Impedance matching is important, otherwise reflections will cause performance degradation or even prevent the GigaSTaR<sup>®</sup> link from working. Please note that the Optical Transceiver Modules, the GigaSTaR<sup>®</sup> devices and all matching circuits are high frequency components and therefore require proper termination.

**DETAILS ABOUT THE SERIAL INTERFACE**

The described Optical Module (INFINEON type V23826-K305-C373) has PECL inputs with differential impedance of 100 Ω. The data outputs feature an internal Open Line Termination and are able to drive a load of 50 Ω to GND or 100 Ω differential.

Data inputs and outputs have internal coupling capacitors. Without the need for biasing the inputs and outputs of the Optical Module it can easily be adapted to the the GigaSTaR<sup>®</sup> Transmitter and Receiver (see figure 3) - output load exactly matches the input load of the GigaSTaR<sup>®</sup> Receiver.

However, it is required to limit the maximum input current of the GigaSTaR<sup>®</sup> Receiver. Therefore the maximum output levels of the Optical Module have to be translated in a way that the maximum input limits of the GigaSTaR<sup>®</sup> Receiver will not be exceeded.

In this case it is necessary to implement an attenuation network between the outputs of the Optical Module and the serial inputs of the GigaSTaR<sup>®</sup> Receiver (see figure 3).

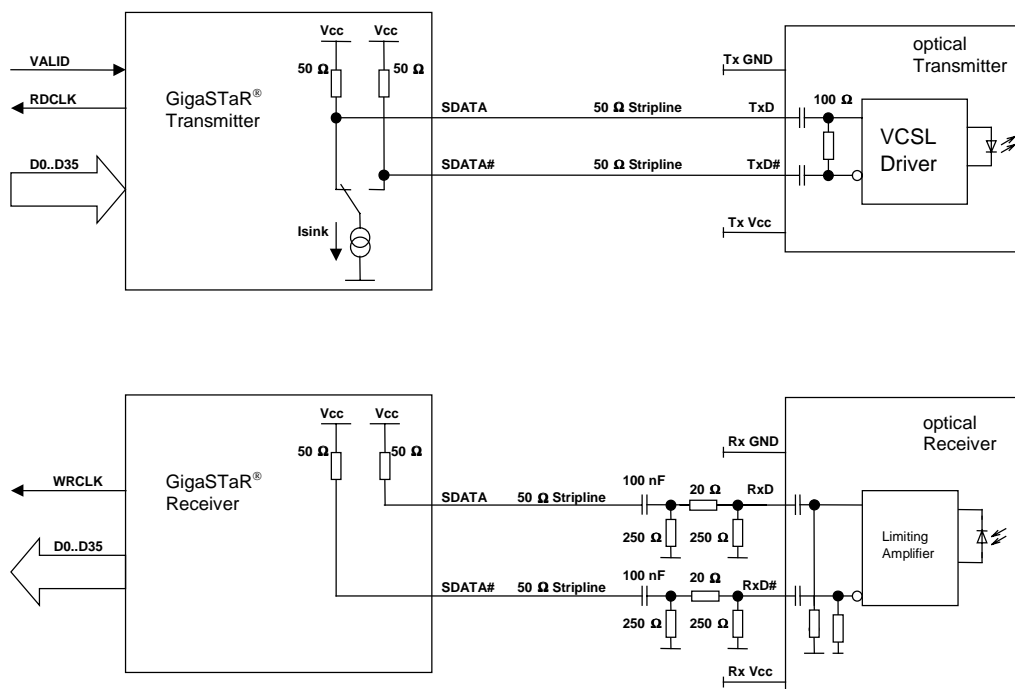

Figure 3: AC-Interconnection Tx- and Rx-GigaSTaR<sup>®</sup> and Optical Module with Attenuation Network

**ATTENUATION NETWORK**

If the output level of the Optical Module exceeds the GigaSTaR<sup>®</sup> Receiver's input level the drawn current will cause damage to the serial RF-interface. In this case an attenuation network and additional coupling capacitors have to be implemented (see figure 3).

For a particular application the following equations may be used to calculate the attenuation network:

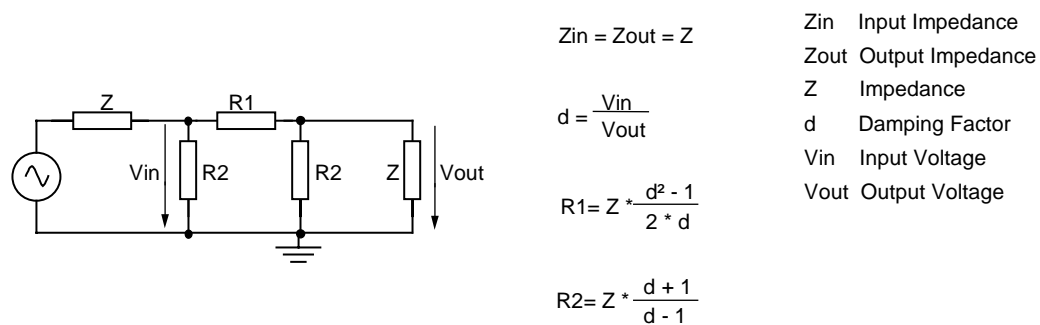

Figure 4: Equations for calculating an attenuation network

The standard input and output impedance is 50 Ω. The damping factor depends on the output level driven by the Optical Module and therefore has to be calculated individually for each implementation. The maximum input voltage swing of the GigaSTaR<sup>®</sup> Receiver is 800 mV (differential).

Please note that it is necessary to implement one of the mentioned attenuation networks for each serial line.

**EXAMPLE**

Assuming the following:

differential output level of the optical receiver:  $V_{outdiff} = 1.2 V$

differential input level of the GigaSTaR<sup>®</sup> Receiver:  $V_{indiff} = 0.8 V$  and  $Z = 50 \Omega$ .

For the attenuation network the values can be calculated as follows:

$$Z = 50 \Omega$$

$$d = \frac{V_{outdiff}}{V_{indiff}} = \frac{1.2 V}{0.8 V} = 1.5$$

$$R1 = Z * \frac{d^2 - 1}{2 * d} = 50 \Omega * \frac{1.5^2 - 1}{2 * 1.5} = 20.8 \Omega$$

$$R2 = Z * \frac{d + 1}{d - 1} = 50 \Omega * \frac{1.5 + 1}{1.5 - 1} = 250 \Omega$$

## COMPONENTS

For technical details regarding the optical modules (V23826-K305-C373) please refer to the product data sheets available on the Infineon Web-page: <http://www.infineon.com/fiberoptics>

Any technical details of the fiber optic cable can be obtained from DIAMOND, Echterdingen, Germany <http://www.diamond.de/> (also available in English)

### Inova Semiconductors GmbH

Ismaninger Str. 3

D-81675 Munich, Germany

Phone: +49 (0)89 / 45 74 75 - 60

Fax: +49 (0) 89 / 45 74 75 - 88

Email: [info@inova-semiconductors.de](mailto:info@inova-semiconductors.de)

URL: <http://www.inova-semiconductors.com>



is a registered trademark of Inova Holding GmbH.



is a registered trademark of Inova Semiconductors GmbH.

All other trademarks or registered trademarks are the property of their respective holders.

Inova Semiconductors GmbH does not assume any liability arising out of the applications or use of the product described herein; nor does it convey any license under its patents, copyright rights or any rights of others.

Inova Semiconductors products are not designed, intended or authorized for use as components in systems to support or sustain life, or for any other application in which the failure of the product could create a situation where personal injury or death may occur.

The information contained in this document is believed to be current and accurate as of the publication date. Inova Semiconductors GmbH reserves the right to make changes at any time in order to improve reliability, function or performance to supply the best product possible. Inova Semiconductors GmbH assumes no obligation to correct any errors contained herein or to advise any user of this text of any correction if such be made.

© Inova Semiconductors GmbH 2001. All rights reserved.