

HANSER automotive

electronics ■ systems



24

Inova Semiconductors
**Rundumsicht
in HD-Qualität**

44

Frank van Meel,
Leiter Strategie Elektromobilität
**Die Elektrostrategie
von AUDI**



FUJITSU
shaping tomorrow with you

20

Skalierbare Systemlösungen von Fujitsu Semiconductor Europe

SoCs für hybride Dashboards



FULLY DIGITAL HD CAMERAS WITH
ONLY TWO ACTIVE COMPONENTS

The new APIX2
Link for all
display and camera
applications in the vehicle.

Round View in HD quality

The new Inova Semiconductors 3Gbit/s Automotive Pixel Link - the APIX2 - has been available since the fall. Apart from its use in display applications, the versatile link is also increasingly used as a camera link since it communicates perfectly with the latest HD megapixel sensor generations of Omnivision and Aptina. In addition to a fully digital 2-chip camera module from Supertech, Inova Semiconductors is also exhibiting a HD quality round-view system, including pedestrian detection, at "Embedded World".

Cameras in vehicles have for many years already been considered to be a future key application of vehicle electronics. It took almost a decade, however, for these systems to assert themselves in the market – but they are now making their presence felt. Aside from electromobility, Advanced Driver Assistance Systems are presently the key topic in automobile electronics. Analysts and leading suppliers forecast a 400% growth in Europe and North America within the next five years for the imaging camera market alone, while the share of multi-camera systems with four or more sensors – for round-view systems for instance – is expected to increase at 27% CAGR - more than proportionally compared to simple base level cameras (20% CAGR). And a new legal regulation is being introduced in North America as well: A draft bill issued by the US Department of Transportation provides that, as from 1 September 2014, it will be mandatory for all newly registered vehicles up to 5 tons to be equipped with rear view cameras - implying a significant increase in camera system sales as from 2012: Instead of 19.1 million vehicles as originally estimated for the years 2011 to 2017, iSuppli now envisages more than 71 million vehicles – virtually quadrupling. These figures by market researchers do not, however, merely reflect the ambitious plans of vehicle manufacturers – the vehicle buyers also have a incredible interest. They consider modern Assistance Systems as highly desirable towards improving drivers safety and increasingly demand these when buying a new vehicle.

Many link solutions on the market

Analog rear view cameras have been around for about 10 years already, especially in Japanese cars. The European Brussels-based organization ERTICO actually made a first attempt in 2004 already to define a uniform digital transmission standard with a view to a clear improvement in image quality. But even today, seven years down the line, the industry is still far from an accepted and uniform standard. For financial reasons, analog systems are still in use today although, slowly but surely, they now appear to be past their peak. The trend is set by new, increasingly efficient camera sensors and is clearly leading to digital, higher quality transmission, and the developer is spoilt for choice here. Classical bus systems such as Ethernet, IEEE1394 (FireWire), MOST and USB are competing with point-to-point links from Inova Semiconductors, Maxim and National Semiconductors; the images are transmitted in real time, compressed or uncompressed, depending on available link bandwidth.

Another market development now also ensures that this connection between sensor and image processing unit assumes a key function. The past problem of two competing system concepts – the so-called "smart camera" which processes the images directly and the "dumb camera" which relegates image processing to a central graphics processor – has now largely been solved: Problems with power dissipation in the local CPU, bulky enclosures – on the windshield, for instance – and sensor use restrictions in various applications have led to virtually only dumb camera systems being used in new developments. These com-

prise three components: a rather compact, universal camera module which is easily fitted to the various "camera positions" in the vehicle – all mirrors, tailgate and fender, among other – and which has a link to the central graphics processor which processes the images and also controls the camera via the link. Two of these three components – the image sensor and graphics processor - have recently become tremendously more powerful: The Omnivision HDR megapixel sensor OV10630, introduced in the fall, can for instance, capture high resolution images of up to 1280 x 800 pixels and at 30 frames per second. The special high dynamic range (HDR) technology ensures that a high contrast of 100 dB is achieved even with color images and also 110 dB for monochrome - at high light sensitivity. The sensor can transmit the data in YUV or RAW format, depending on whether the image data are displayed or evaluated by special algorithms. And the modern graphics processors such as the Tegra series of nVidia are also these days capable of processing the sensor's data flood in real time.

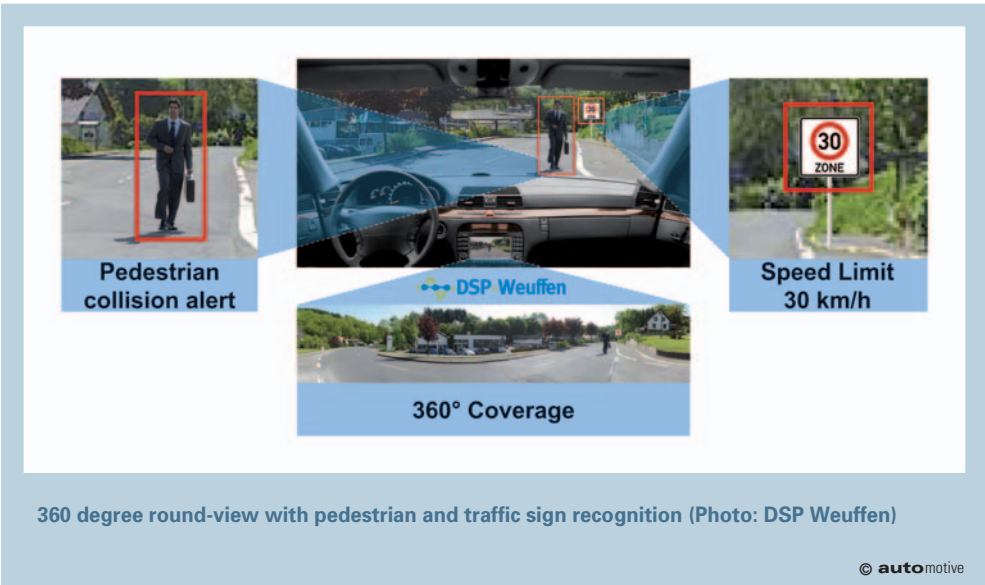

360 degree round-view with pedestrian and traffic sign recognition (Photo: DSP Weuffen)

© automotive

Bottleneck camera link

The camera link between sensor and processor is generally the bottleneck today; it determines the quality of the entire system. Such a connection should ideally function like a piece of wire: The link should transmit the image data from the sensor to the processor precisely and without delay and also accurately and reliably transmit the processor control signals in the other direction. Only in this way

can the processor accurately control the sensor to guarantee usable images at all times, even in critical situations of highly dynamic images and extreme contrast – such as with high speed travel on a freeway and sharp light/shadow transitions. But this is where many links are restricted and limited due to their mode of operation. Bus systems suffer from low bandwidths, resulting in strong compression with high latency periods and reduction in contrast / image detail, while the serial Gigabit links suffer from physical effects such as jitter or, depending on the design, limitations in the transmission of control data.

APIX – the data highway also for cameras

With the 1 Gbit/s APIX Link recently introduced in 2007 and especially the 3 Gbit/s APIX2 Link recently exhibited at the "electronica", Inova Semiconductors is addressing all these topics with the aim of very closely approaching this ideal of a "piece of wire". The APIX concept – both APIX1 and now also APIX2 – is based on a complex clocking system. Unlike

the Gigabit links of other manufacturers, the serial transmission clock is, in this case, not derived from the pixel clock of the graphics chip or camera sensor but it is generated by an independent and complex clocking system: The pixel data are streamed to the processor uncompressed and in real time, similar to a conveyor belt. Control data can be transmitted bi-directionally and virtually latency free at 187.5 Mbit/s, simultaneously and independent of the camera images and their blanking times (Picture 1). The control data are additionally protect-

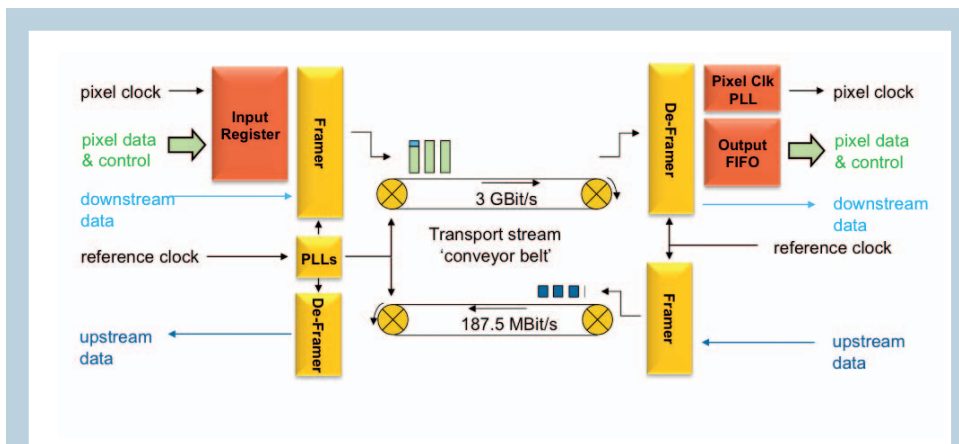

Picture 1: The APIX Link mode of operation: Data are streamed in real time – continuously, in both directions and totally independent of image-dependent parameters such as blanking time or pixel clock jitter.

© automotive

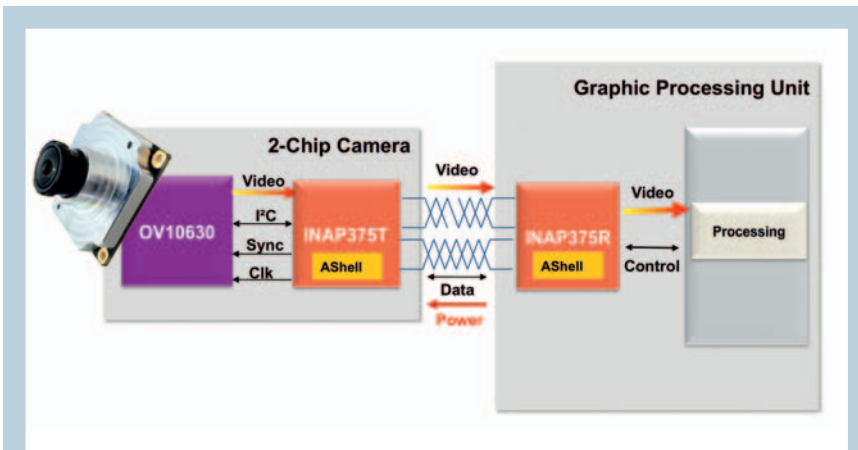

Picture 2: Camera link: with APIX2: An STP 4-wire connection between camera and GPU for uncompressed transmission of image and control data in real time and for power supply to the sensor.

© automotive

ed by a protocol, the so-called AShell (Automotive Shell), which was developed by Inova Semiconductors and fully implemented in hardware. Reliable real-time processor to sensor communication is a must, especially with safety-related applications such as airbag release or active intervention in hazardous situations. The processor must always be able to unequivocally verify that the current image contains valid data before triggering braking or steering actions. The APIX2 transmits a complete camera image from sensor to processor with a mere 3...4 μsec latency. And the control signals from the processor are back at the sensor in around 75 μsec – fully deterministic and independent of image content, blanking, pixel clock or jitter. In this way, the APIX2 Link always assures communication between the sensor and the GPU, even in extreme situations, thus very closely approaching the functionality of a "piece of wire".

Fully digital 2-chip camera module and round-view in HD quality

In addition to the high bandwidth and real time capability, the APIX2 also has functionalities to meet specifically the demands of modern megapixel sensors. The APIX transmitter device can, for instance, work with a pixel clock of up to 120 MHz; the camera needs no additional logic for clock conversion even at the highest sensor resolution and maximum frame rate. The bi-directional communication channels offer the developer numerous options in this respect: Both the APIX-Tx transmitter device and the sensor itself can be fully remotely configured by the graphic processor and controlled in real time. The local PLD (single) or microcontroller usually required for camera configuration by other links fall away without substitution. With APIX2, fully digital HD cameras can, for the first time, be designed with only two active components – a sensor and APIX Tx. And the APIX architecture also offers very special features that cannot be achieved with any other link, but which are important especially for stereo and multicamera systems. Not only is the APIX2 capable of transmitting two fully independent streams each with its own pixel clock,

but the integrated GPIO interface allows the central graphics processor to synchronize the sensors, virtually in real time ($t_{pd} < 400 \text{ ns}$). With APIX, image transmission and bi-directional sensor-processor communication is via the standard and popular 4-wire STP Gigabit cable [e.g. from Leoni or Ernst&Engbring], which simultaneously also supplies the sensor and the Tx device with power through "Power over APIX". (Picture 2)

Inova Semiconductors exhibited a first 2-chip camera module from the Taiwanese manufacturer Supertech, with APIX2 Tx and Omnivision's latest HDR megapixel sensor OV10630, at the "electronica" in November. The 2nd generation of this module will now be on show at "Embedded World" from the 1st to the 3rd of

March. The latest Rosenberger connector system with its particularly compact and waterproof design has here replaced the standard HSD connector (Picture 3).

Inova, together with NVIDIA and the camera specialist DSP Weuffen, will exhibit an innovative Advanced Driver Assistance System to demonstrate the powerful APIX technology at "Embedded World". Four cameras, with the latest Omnivision HDR sensor OV10630, are connected to a CPU via the APIX2 Link. Based on the four camera images, a fully digital round-view image is then computed in HD resolution (Picture 4). Special NVIDIA algorithms scan this image for pedestrians, dynamically and in real time, quickly alerting the driver of anyone crossing the road or getting dangerously close. But, in addition to introducing the powerful 3-Gbit/s link technology in the market with APIX2, Inova Semiconductors is aiming to offer customers complete and coordinated system solutions "around APIX" – from sensor to graphics processor – and therefore



Picture 3: New 4-pin Gigabit camera connector from Rosenberger: compact and waterproof design (Photo: Rosenberger).

© automotive

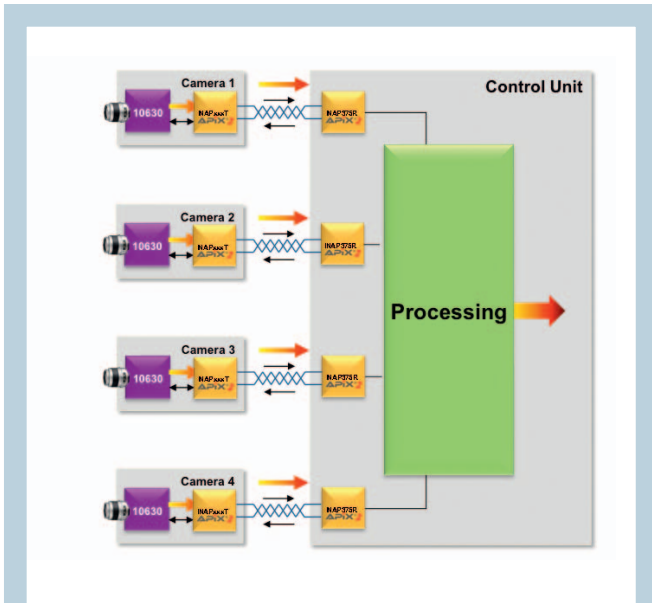

Picture 4: Round-view system with four cameras, APIX2 Link and GPU.

© automotive

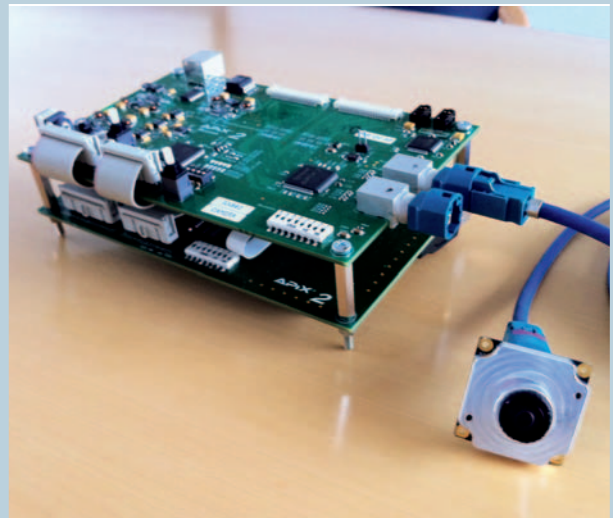

Picture 5: The new APIX2 Demo kit ADK2 with fully digital 2-chip Supertech camera module (Omnivision sensor OV10630 + APIX2 INAP375T) with flexible 3-Gbit/s cable from Ernst&Engbring (Photo: Inova Semiconductors).

© automotive

cooperates closely with other manufacturers such as the two leading camera sensor suppliers Omnivision and Aptina, for instance.

Not only a link but a complete system solution

Apart from APIX application boards (Picture 5), layout aids and software tools offered by Inova Semiconductors itself, the company's partners are already offering a variety of products and system solutions based on this innovative technology. This includes more complex SoC products with fully integrated APIX interfaces such as graphics processors, controllers and FPGAs from Fujitsu, Toshiba and Xilinx for instance, or connector and cable components tested for high Gigabit data rates from Rosenberger and Ernst&Engbring, as well as complete camera modules already from Supertech in Taiwan.

System integrators such as DSP Weuffen in Amtzell or the Duisburg company Helion, specialized in the development of camera systems, are also offering APIX-based hardware and software solutions already. Inova Semiconductors themselves is developing another chip, designed for use especially for compact camera modules. An additional APIX2 transmitter device will be released in the summer of 2011 already, with interfaces and package optimally matched to modern HD sensors – to enable the design of even more compact camera modules. (oe) Visit Inova Semiconductors in Hall 9, Stand 555, at Embedded World.

Compiled using documentation of the companies Inova Semiconductors, Omnivision, nVIDIA, DSP Weuffen, Supertech and Rosenberger.

@ Inova Semiconductors
www.inova-semiconductors.de